

# Besam Sliding Door Operator Besam UniSlide T

ASSA ABLOY

ASSA ABLOY Entrance Systems

The global leader in  
door opening solutions



The Besam telescopic sliding door operator Besam UniSlide T maximises the opening width and provides an impressive solution when space is of prime criteria

### Impressive entrances

Besam UniSlide T is available for bi-parting/four leaf and single slide/two leaf doors. The Besam UniSlide T can be integrated as part of Besam Automatic Door Systems but it can also be adapted to a wide range of different door and customer requirements.

### High performance – Easy installation

Many of the most valuable features and innovations that characterize Besam's strive for optimal function and performance are combined in Besam UniSlide T. With all units completely assembled in the support beam it is just as easy to install as a replacement as for new installations. Although it is very small and slim in appearance, it is entirely suitable for the heaviest duty applications.

### Technical specifications

Power supply	120 V AC -10% to 240 V AC +10%; 50/60 Hz
Power consumption	max. 250 W
Recommended max. door weight	Besam UniSlide T-2 75 kg/door leaf Besam UniSlide T-1 100 kg/door leaf
Clear opening	Besam UniSlide T-2 1600 – 4000 mm Besam UniSlide T-1 1000 – 3990 mm
Opening and closing speed	variable up to 1.4 m/s (4 leaves)
Hold open time	0 – 60 s
Ambient temperature	-20°C to +50°C
Relative humidity (non-condensing)	Max 85%

### No compromise on safety

To permit safe passage between closing doors, the doors immediately reverse if an obstruction is detected, then resume their interrupted movement at low speed to check whether the obstruction has disappeared or not. If an obstruction is detected between opening doors and surrounding walls or interior fittings, the door immediately stops and then closes after a time delay.

The safety can be further improved by using a Besam presence detection system. People or objects in the doorway are detected and the door is then prevented from closing until it is safe to do so.

### Self-monitoring

The microprocessor has an integral self-monitoring device which detects any interference or faulty signals in door operation and takes necessary measures to ensure a safe operation.

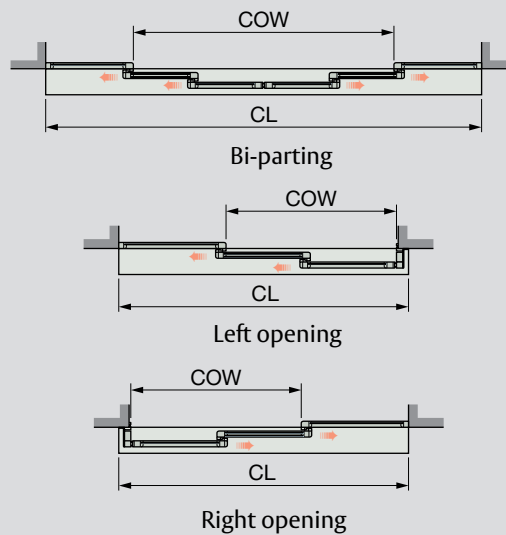
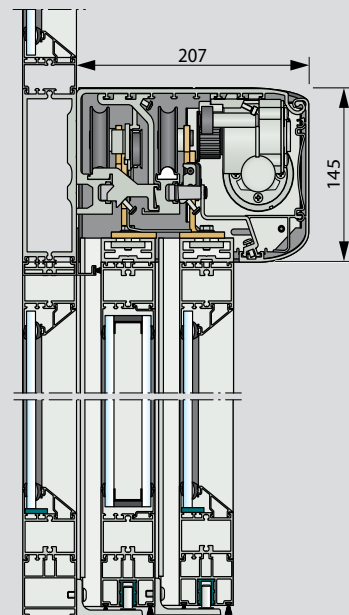

COW = Largeur de passage  
CL = Longueur du capot

### Design

The drive unit, control unit, transmission – or optional emergency unit and electromechanical locking device – are all assembled in the support beam. The drive unit transmits movement to the door leaves by means of tooth belts. The door leaves with integrated or separately mounted door adaptors can be adjusted height-, length- and depth-wise. Journalled steel rollers and sliding tracks made of high-grade plastic give exceptionally smooth and silent operation.

### Emergency

Besam UniSlide T can either be combined with a mechanical emergency unit that automatically opens the doors – or an electronic emergency unit that automatically opens or closes the doors – in the event of a power failure. The Besam UniSlide T can also be interfaced with fire alarms or smoke detectors.

### Models

**Besam UniSlide T-2** – 4 leaves, bi-parting

**Besam UniSlide T-1** – 2 leaves, single slide, right or left opening

### Standard equipment

- Support beam with transmission
- Electronic control unit with plug-in connections and power supply
- Traffic-controlled opening width
- Synchronizing of two operators

### Accessories and Options

- Cover
  - clear anodized aluminium (other anodizing optional)
  - Powdercoat finish
- Door adaptor for doors up to 65 mm thickness made by others
- Programme selectors
- Electronic emergency opening or closing unit
- Mechanical emergency opening unit Break-out unit
- Emergency button
- Besam approach and presence sensor
- Presence detection photocells
- Electromechanical locking (optional SCEC approved)
- Interlocking between two operators
- Key switch
- Besam Automatic Door systems

This equipment should be installed, regularly inspected, maintained and serviced by trained and authorized personnel. Preventive maintenance plans are highly recommended for a proper and safe operation. Talk to your ASSA ABLOY Entrance Systems representative to learn more about our service offering!